

Paranchi manuali a catena serie FH

FH series manual chain hoists

SERIE FH

Portate fino a 5 t

FH SERIES

WLL up to 5 t

CARATTERISTICHE SPECIFICATION

- Compact and robust steel body
- Sure and reliable mechanical brake with safety pawl
- Zinc plated load chain according to EN 818-7
- Trolley wheels with ball bearings
- Safety lugs
- Rubber bumpers
- Corpo di acciaio robusto e compatto
- Freno sicuro e affidabile con saltarello di sicurezza
- Catena di carico elettrozincata a norme EN 818-7
- Ruote carrello su cuscinetti
- Staffe anticarruolamento
- Respingenti in gomma

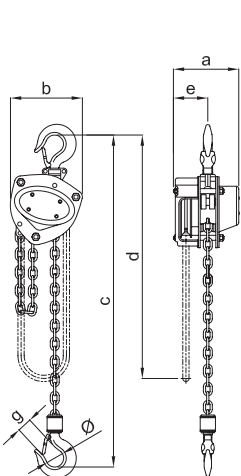

FH/1G

Con gancio di sospensione
With hook suspension

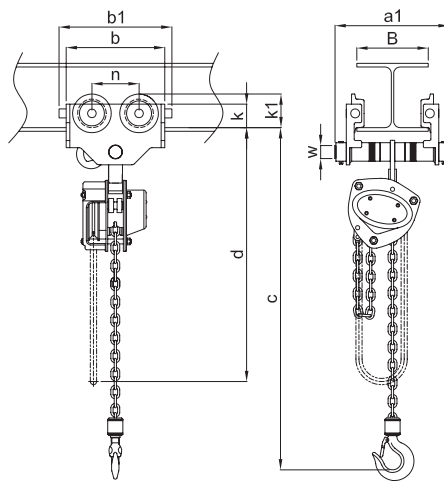

FH/2S

Con carrello a spinta
With plain trolley

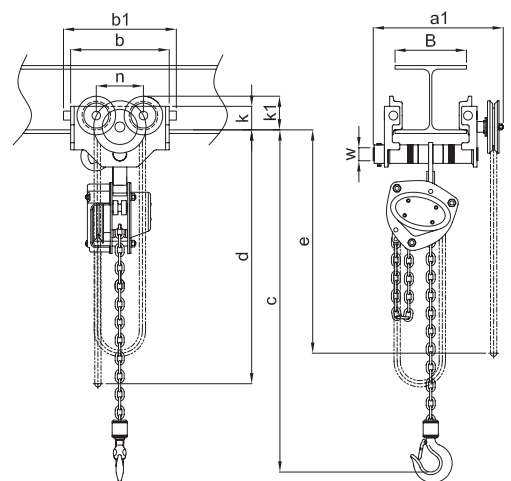

FH/2

Con carrello meccanico
With geared trolley

Paranchi manuali a catena serie FH

FH series manual chain hoists

SERIE FH
Portate fino a 5 t

FH SERIES
WLL up to 5 t

TIPO FH/1G CON GANCIO DI SOSPENSIONE

FH/1G TYPE WITH HOOK SUSPENSION

Portata WLL	Tipo Type	Corsa gancio STD Std Lift	Catena di manovra STD Std hand chain	Sforzo sulla catena di manovra a pieno carico Chain pull to lift full load	Catena svolta per sollevare un metro Chain pulled to lift load 1 m	Carico di prova Test load	Minima quota Min. headroom	Dimensioni Dimensions						Catena di carico Load chain Diametro x tiri Diameter x falls		Peso netto Net weight	Peso per m aggiuntivo di corsa gancio Weight for additional one meter lift
								a	b	d	e	g	ø	mm	n°		
0,25	FH 3S1/1G	3	2,5	20	22	0,37	280	106	108	3000	68	24	31	4	1	6,5	1,3
0,5	FH 5S1/1G	3	2,5	25	25	0,75	280	128	130	3000	75	27	35	5	1	9	1,5
1	FH 10S1/1G	3	2,5	29	43	1,5	330	142	150	3000	76	31	40	6,3	1	12	1,8
1,5	FH 15S1/1G	3	2,5	34	57	2,25	360	158	170	3000	80	35	45	7,1	1	15	2,1
2	FH 20S1/1G	3	2,5	35	70	3	385	175	185	3000	88	38	50	8	1	20	2,3
3	FH 30S2/1G	3	2,5	40	115	4,5	510	158	220	3100	80	42	55	7,1	2	23	3,2
5	FH 50S2/1G	3	2,5	40	199	7,5	615	183	255	3100	90	48	65	9	2	37	4,4

TIPO FH/2S CON CARRELLO A SPINTA

FH/2S TYPE WITH PLAIN TROLLEY

Portata WLL	Tipo Type	Corsa gancio STD Std Lift	Catena di manovra STD Std hand chain	Larghezza trave B Flange width B		Raggio minimo curvatura Min. radius curve	Minima quota Min. headroom	Dimensioni Dimensions								Peso netto Net weight	Peso per m aggiuntivo di corsa gancio Weight for additional 1m of lift
				Standard	Option			a1*	b	b1	d	k	k1	n	w		
0,25	FH 3S1/2S	3	2,5	50-152	153-203	800	349 (423)	240	200	240	3000	45	70	100	24	15	1,5
0,5	FH 5S1/2S	3	2,5	50-152	153-203	800	349 (423)	240	200	240	3000	45	70	100	24	15	1,5
1	FH 10S1/2S	3	2,5	64-203	204-305	900	406 (493)	286	246	286	3000	55	80	120	30	25	1,8
1,5	FH 15S1/2S	3	2,5	88-203	204-305	1000	439 (490)	317	276	316	3000	65	90	132	36	35	2,1
2	FH 20S1/2S	3	2,5	88-203	204-305	1000	464 (582)	317	276	316	3000	65	90	132	36	40	2,3

- * Le misure della quota a1 sono riferite a carrelli con perno standard.
- ** Tra parentesi quote con gancio e sospensione.
- * Dimensions a1 are referred to trolleys with standard shaft.
- ** Between bracket dimensions with hook and suspension.

TIPO FH/2 CON CARRELLO MECCANICO

FH/2 TYPE WITH GEARED TROLLEY

Portata WLL	Tipo Type	Corsa gancio STD Std Lift	Catena di manovra STD Std hand chain	Larghezza trave B Flange width B		Raggio minimo curvatura Min. radius curve	Minima quota Min. headroom	Dimensioni Dimensions										Peso netto Net weight	Peso per m aggiuntivo di corsa gancio Weight for additional 1m of lift
				Standard	Option			a1*	b	b1	d	e	k	k1	n	w	Kg		
0,25	FH 3S1/2	3	2,5	50-152	153-203	800	349 (423)	271	200	240	3000	2700	45	70	100	24	19	1,5	
0,5	FH 5S1/2	3	2,5	50-152	153-203	800	349 (423)	271	200	240	3000	2700	45	70	100	24	19	1,5	
1	FH 10S1/2	3	2,5	64-203	204-305	900	406 (493)	329	246	286	3000	2700	55	80	120	30	27	1,8	
1,5	FH 15S1/2	3	2,5	88-203	204-305	1000	439 (490)	344	276	316	3000	2700	65	90	132	36	37	2,1	
2	FH 20S1/2	3	2,5	88-203	204-305	1000	464 (582)	344	276	316	3000	2700	65	90	132	36	42	2,3	
3	FH 30S2/2	3	2,5	100-203	204-305	1200	(748)	346	332	372	3100	2700	85	118	154	42	61	3,2	
5	FH 50S2/2	3	2,5	114-203	204-305	1300	(895)	418	380	405	3100	2700	110	130	170	48	90	4,4	

- * Le misure della quota a1 sono riferite a carrelli con perno standard.
- ** Tra parentesi quote con gancio e sospensione.
- * Dimensions a1 are referred to trolleys with standard shaft.
- ** Between bracket dimensions with hook and suspension.