

## Paranchi elettrici a catena serie KF

KF series electric chain hoists

KITO

**TIPO KF/2**  
Con carrello meccanico

KF/2 TYPE  
With geared trolley

### CARATTERISTICHE SPECIFICATION

- Power supply 230-400V / 50-60Hz
- Control Voltage 48 V
- IP 54 enclosure protection
- Galvanized chain resistant to fatigue and wear
- Chain container
- Geared trolley for precise movements and short distances
- Trolleys wheels with life lubricated bearings
- Single shaft trolley to share the load on the 4 wheels
- Lugs provide protection from falling off the rail
- Rubber bumpers
- Wheels profile suitable for flat or tapered beams

- Alimentazione 230-400V / 50-60Hz
- Apparecchiatura in bassa tensione 48 V
- Protezione paranco IP 54
- Catena zincata resistente alla fatica e alla corrosione
- Sacco raccogli catena
- Carrello con comando a catena per movimenti precisi e percorsi corti
- Ruote carrello su cuscinetti lubrificati a vita
- Carico sempre distribuito sulle 4 ruote poiché le piastre ruotano sul perno del carrello
- Staffe anticarrucolamento
- Respingenti in gomma
- Idonei a scorrere su travi ad ali piatte o inclinate grazie al profilo delle ruote

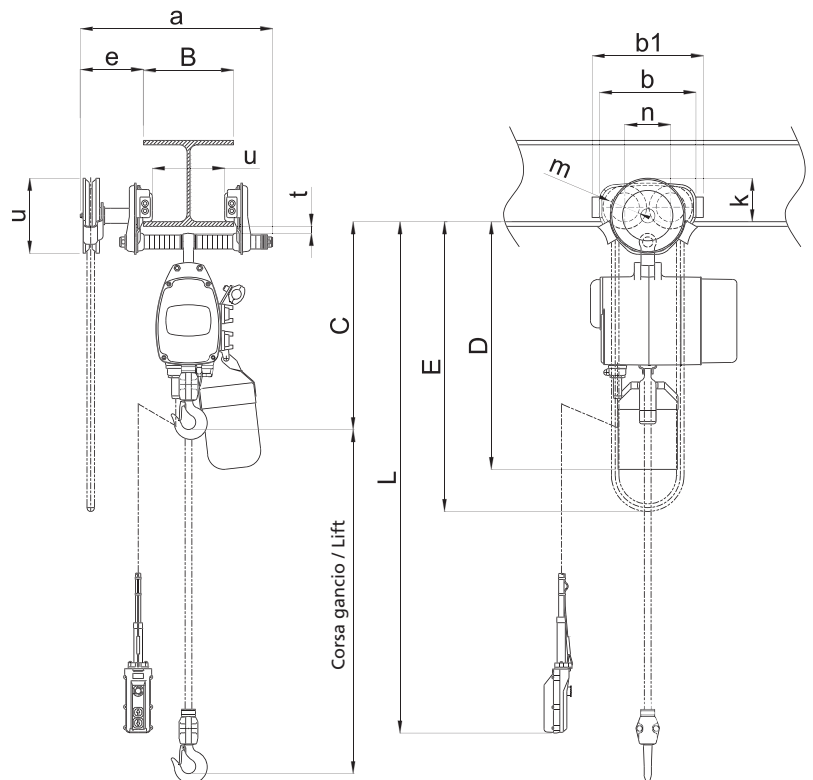

### DATI TECNICI TECHNICAL DATA

	Portata WLL t	Tipo Type	Corsa gancio STD Std lift m	Cavo pulsantiera STD L Std push button cord m	Catena manovra STD E STD hand chain m	Velocità sollevamento Lifting speed 50 Hz m/min.	Motore sollevamento Lifting motor		Larghezza trave B Flange width B		Raggio minimo curvatura Min. radius curve mm	Peso netto Net weight Kg	Peso per ogni metro addizionale di corsa gancio Weight for additional one meter of lift Kg
							Potenza Output kW	R.I. ED %	Standard mm	Option mm			
1 vel. sollev. 1 speed	125 kg	KF 20S1/2	3.0	2.0	2.5	8.0	0.45	50	58±163	164±305	1300	41	0,55
	250 kg	KF 20S2/2	3.0	2.0	2.5	4.0	0.45	50	58±163	164±305	1300	45	1,10
	250 kg	KF 25S1/2	3.0	2.0	2.5	8.0	0.45	50	58±163	164±305	1300	41	0,55
	500 kg	KF 25S2/2	3.0	2.0	2.5	4.0	0.45	50	58±163	164±305	1300	45	1,10
	500 kg	KF 50S1/2	3.0	2.0	2.5	7.0	0.80	50	58±163	164±305	1300	54	0,85
	1	KF 50S2/2	3.0	2.0	2.5	3.5	0.80	50	58±163	164±305	1300	59	1,70
	1	KF 100S1/2	3.0	2.0	2.5	6.5	1.50	50	58±163	164±305	1300	69	1,10
2 vel. sollev. 2 speed	2	KF 100S2/2	3.0	2.0	2.5	3.3	1.50	50	82±204	205±305	1500	78	2,20
	125 kg	KF 20S1A/2	3.0	2.0	2.5	8.0/2.7	0.45/0.15	40/40	58±163	164±305	1300	41	0,55
	250 kg	KF 20S2A/2	3.0	2.0	2.5	4.0/1.3	0.45/0.15	40/40	58±163	164±305	1300	45	1,10
	250 kg	KF 25S1A/2	3.0	2.0	2.5	8.0/2.7	0.45/0.15	40/40	58±163	164±305	1300	41	0,55
	500 kg	KF 25S2A/2	3.0	2.0	2.5	4.0/1.3	0.45/0.15	40/40	58±163	164±305	1300	45	1,10
	500 kg	KF 50S1A/2	3.0	2.0	2.5	7.0/2.3	0.80/0.27	40/40	58±163	164±305	1300	54	0,85
	1	KF 50S2A/2	3.0	2.0	2.5	3.5/1.2	0.80/0.27	40/40	58±163	164±305	1300	59	1,70
2 speed	1	KF 100S1A/2	3.0	2.0	2.5	6.5/2.2	1.50/0.50	40/40	58±163	164±305	1300	69	1,10
	2	KF 100S2A/2	3.0	2.0	2.5	3.3/1.1	1.50/0.50	40/40	82±204	205±305	1500	78	2,20

- Tutti i modelli sono disponibili con comando diretto o in bassa tensione. Su richiesta carrelli per raggi di curva inferiori.
- All models available with direct voltage or low voltage. Upon demand available trolleys for smaller radius curve.

	Portata WLL t	Tipo Type	Ingombro minimo Min headroom C mm	Dimensioni Dimensions										
				D mm	a mm	b mm	b1 mm	e mm	g mm	k mm	m mm	n mm	t mm	u mm
1 vel. sollev. 1 speed	125 kg	KF 20S1/2	525	615 [705]	345	236	272	152	24	106	71	112	28	B-48
	250 kg	KF 20S2/2	555	615 [705]	345	236	272	152	24	106	71	112	28	B-48
	250 kg	KF 25S1/2	525	615 [705]	345	236	272	152	24	106	71	112	28	B-48
	500 kg	KF 25S2/2	555	615 [705]	345	236	272	152	24	106	71	112	28	B-48
	500 kg	KF 50S1/2	565	755 [835]	345	236	272	152	34	106	71	112	28	B-48
	1	KF 50S2/2	630	755 [835]	345	236	272	152	31	106	71	112	28	B-48
	1	KF 100S1/2	625	860 [900]	345	236	272	152	31	106	71	112	28	B-48
2 vel. sollev. 2 speed	2	KF 100S2/2	775	940 [980]	385	280	316	154	37	112	85	131	34	B-57
	125 kg	KF 20S1A/2	525	615 [705]	345	236	272	152	24	106	71	112	28	B-48
	250 kg	KF 20S2A/2	555	615 [705]	345	236	272	152	24	106	71	112	28	B-48
	250 kg	KF 25S1A/2	525	615 [705]	345	236	272	152	24	106	71	112	28	B-48
	500 kg	KF 25S2A/2	555	615 [705]	345	236	272	152	24	106	71	112	28	B-48
	500 kg	KF 50S1A/2	565	755 [835]	345	236	272	152	34	106	71	112	28	B-48
	1	KF 50S2A/2	630	755 [835]	345	236	272	152	31	106	71	112	28	B-48
2 speed	1	KF 100S1A/2	625	860 [900]	345	236	272	152	31	106	71	112	28	B-48
	2	KF 100S2A/2	775	940 [980]	385	280	316	154	37	112	85	131	34	B-57

- Le dimensioni ( ) della quota "D" è riferita a paranchi con sacco raccogli catena grande.
- Dimensions in brackets for measure "D" are data for large size chain container.