

Paranchi elettrici a catena serie KF

KF series electric chain hoists

KITO

TIPO KF/2S
Con carrello a spinta

KF/2S TYPE
With plain trolley

CARATTERISTICHE SPECIFICATION

- Power supply 230-400V / 50-60Hz
- Control Voltage 48 V
- IP 54 enclosure protection
- Galvanized chain resistant to fatigue and wear
- Chain container
- Trolleys wheels with life lubricated bearings
- Single shaft trolley to share the load on the 4 wheels
- Lugs provide protection from falling off the rail
- Rubber bumpers
- Wheels profile suitable for flat or tapered beams

- Alimentazione 230-400V / 50-60Hz
- Apparecchiatura in bassa tensione 48 V
- Protezione paranco IP 54
- Catena zincata resistente alla fatica e alla corrosione
- Sacco raccogli catena
- Ruote carrello su cuscinetti lubrificati a vita
- Carico sempre distribuito sulle 4 ruote poiché le piastre ruotano sul perno del carrello
- Staffe anticarrucolamento
- Respingenti in gomma
- Idonei a scorrere su travi ad ali piatte o inclinate grazie al profilo delle ruote

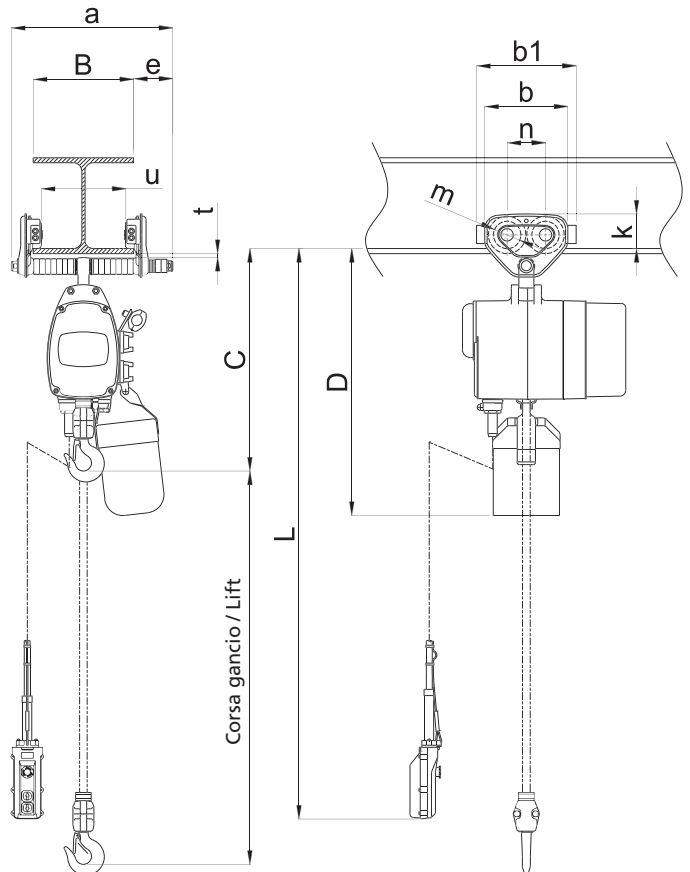

DATI TECNICI TECHNICAL DATA

	Portata WLL t	Tipo Type	Corsa gancio STD Std lift m	Cavo pulsantiera STD L Std push button cord m	Velocità sollevamento Lifting speed 50 Hz m/min.	Motore sollevamento Lifting motor		Larghezza trave B Flange width B		Raggio minimo curvatura Min. radius curve mm	Peso netto Net weight Kg	Peso per ogni metro addizionale di corsa gancio Weight for additional one meter of lift Kg
						Potenza Output kW	R.I. ED %	Standard mm	Option mm			
1 vel. sollev. 1 speed	125 kg	KF 20S1/2S	3.0	2.0	8.0	0.45	50	50±163	164±305	1100	33	0,55
	250 kg	KF 20S2/2S	3.0	2.0	4.0	0.45	50	50±163	164±305	1100	37	1,10
	250 kg	KF 25S1/2S	3.0	2.0	8.0	0.45	50	50±163	164±305	1100	33	0,55
	500 kg	KF 25S2/2S	3.0	2.0	4.0	0.45	50	50±163	164±305	1100	37	1,10
	500 kg	KF 50S1/2S	3.0	2.0	7.0	0.80	50	50±163	164±305	1100	46	0,85
	1	KF 50S2/2S	3.0	2.0	3.5	0.80	50	58±163	164±305	1300	54	1,70
	1	KF 100S1/2S	3.0	2.0	6.5	1.50	50	58±163	164±305	1300	66	1,10
2 vel. sollev. 2 speed	2	KF 100S2/2S	3.0	2.0	3.3	1.50	50	82±204	205±305	1500	76	2,20
	125 kg	KF 20S1A/2S	3.0	2.0	8.0/2.7	0.45/0.15	40/40	50±163	164±305	1100	33	0,55
	250 kg	KF 20S2A/2S	3.0	2.0	4.0/1.3	0.45/0.15	40/40	50±163	164±305	1100	37	1,10
	250 kg	KF 25S1A/2S	3.0	2.0	8.0/2.7	0.45/0.15	40/40	50±163	164±305	1100	33	0,55
	500 kg	KF 25S2A/2S	3.0	2.0	4.0/1.3	0.45/0.15	40/40	50±163	164±305	1100	37	1,10
	500 kg	KF 50S1A/2S	3.0	2.0	7.0/2.3	0.80/0.27	40/40	50±163	164±305	1100	46	0,85
	1	KF 50S2A/2S	3.0	2.0	3.5/1.2	0.80/0.27	40/40	58±163	164±305	1300	54	1,70
2 speed	1	KF 100S1A/2S	3.0	2.0	6.5/2.2	1.50/0.50	40/40	58±163	164±305	1300	66	1,10
	2	KF 100S2A/2S	3.0	2.0	3.3/1.1	1.50/0.50	40/40	82±204	205±305	1500	76	2,20

- Tutti i modelli sono disponibili con comando diretto o in bassa tensione. Su richiesta carrelli per raggi di curva inferiori.
- All models available with direct voltage or low voltage. Upon demand available trolleys for smaller radius curve.

	Portata WLL t	Tipo Type	Ingombro minimo Min headroom C mm	Dimensioni Dimensions											
				D mm	a mm	b mm	b1 mm	e mm	g mm	k mm	m mm	n mm	t mm	u mm	
1 vel. sollev. 1 speed	125 kg	KF 20S1/2S	500	600 [690]	204	182	212	212	46	24	76	60	84	19	B-45
	250 kg	KF 20S2/2S	540	600 [690]	204	182	212	212	46	24	76	60	84	19	B-45
	250 kg	KF 25S1/2S	500	600 [690]	204	182	212	212	46	24	76	60	84	19	B-45
	500 kg	KF 25S2/2S	540	600 [690]	204	182	212	212	46	24	76	60	84	19	B-45
	500 kg	KF 50S1/2S	550	740 [820]	204	182	212	212	46	34	76	60	84	19	B-45
	1	KF 50S2/2S	630	755 [835]	249	236	272	272	46	31	95	71	112	28	B-48
	1	KF 100S1/2S	625	860 [900]	249	236	272	272	56	31	95	71	112	28	B-48
2 vel. sollev. 2 speed	2	KF 100S2/2S	775	940 [980]	300	280	316	316	69	37	112	85	131	34	B-57
	125 kg	KF 20S1A/2S	500	600 [690]	204	182	212	212	46	24	76	60	84	19	B-45
	250 kg	KF 20S2A/2S	540	600 [690]	204	182	212	212	46	24	76	60	84	19	B-45
	250 kg	KF 25S1A/2S	500	600 [690]	204	182	212	212	46	24	76	60	84	19	B-45
	500 kg	KF 25S2A/2S	540	600 [690]	204	182	212	212	46	24	76	60	84	19	B-45
	500 kg	KF 50S1A/2S	550	740 [820]	204	182	212	212	46	34	76	60	84	19	B-45
	1	KF 50S2A/2S	630	755 [835]	249	236	272	272	46	31	95	71	112	28	B-48
2 speed	1	KF 100S1A/2S	625	860 [900]	249	236	272	272	56	31	95	71	112	28	B-48
	2	KF 100S2A/2S	775	940 [980]	300	280	316	316	69	37	112	85	131	34	B-57

- Le dimensioni () della quota "D" è riferita a paranchi con sacco raccogli catena grande.
- Dimensions in brackets for measure "D" are data for large size chain container.