

DATI TECNICI

TECHNICAL DATA

The Ni-Cr-Mo steel chains meet the requirements of the EN 818 standards.

The boro steel manganese chains have the dimensional tolerances of the alloy steel chains, and they respect all parameters with the exception of the composition of the steel. Are guaranteed values of breaking elongation, to the breaking stress and consequently to the maximum working load.

TECHNICAL DATA

- Breaking elongation: **min 20%**
- Stress at load capacity limit: **200 N/mm²**
- Stress at load capacity limit: **500 N/mm²**
- Breaking stress: **800 N/mm²**

Le catene di acciaio legato al Ni-Cr-Mo e gli accessori sono prodotti in accordo ai requisiti delle Norme EN 818.

Le catene zincate in acciaio al boro manganese hanno le tolleranze dimensionali delle catene in acciaio legato, e ne rispettano tutti i parametri, ad eccezione della composizione dell'acciaio.

Sono garantiti i valori relativi all'allungamento a rottura, al carico di rottura e di conseguenza al carico massimo di utilizzo.

DATI TECNICI

- Allungamento a rottura: **min 20%**
- Sollecitazione al carico di lavoro: **200 N/mm²**
- Sollecitazione al carico di prova: **500 N/mm²**
- Sollecitazione alla rottura: **800 N/mm²**

MARCATURE

MARKING

The Grade 8 chains are marked with the symbol of identification of the manufacturer and the quality grade (8).

Each chain sling is marked with the number of identification of the lot production. All the chain sling are delivered complete with the identification tag and EC declaration of conformity.

Le catene di Grado 8 sono marcate con il simbolo di identificazione del produttore e il grado qualitativo (8).

Ogni catena è marcata con il numero di identificazione del lotto di produzione. Tutti i tiranti vengono consegnati completi di targhetta metallica di identificazione e dichiarazione di conformità CE.



PORTATA DELLE IMBRAGATURE

LOAD CAPACITIES

Coefficiente di sicurezza 4 Safety factor 4	1 braccio 1 leg		2 bracci 2 legs				3 e 4 bracci 3 and 4 legs		Anello continuo Endless chain sling	Imbragatura a canestro Loop chains				
Angolo β Angle β	-	-	0° - 45°	45° - 60°	0° - 45°	45° - 60°	0° - 45°	45° - 60°	0° - 45°	0° - 45°	45° - 60°	0° - 45°	45° - 60°	
Fattore di carico Load factor	1	0,8	1,4	1	1,12	0,8	2,1	1,5	1,6	1,4	1	2,1	1,5	
Catena tipo Chain type	Portata Kg WLL Kg													
WB 7	7	1500	1200	2120	1500	1700	1200	3150	2240	2500	2120	1500	3150	2240
WB 8	8	2000	1600	2800	2000	2240	1600	4250	3000	3150	2800	2000	4250	3000
WB 10	10	3150	2500	4250	3150	3550	2500	6700	4750	5000	4250	3150	6700	4750
WB 13	13	5300	4250	7500	5300	5900	4250	11200	8000	8500	7500	5300	11200	8000
WB 16	16	8000	6300	11200	8000	9000	6300	17000	11800	12500	11200	8000	17000	11800
WB 20	20	12500	10000	17000	12500	14000	10000	26500	19000	20000	17500	12500	26200	18700
WB 22	22	15000	12000	21200	15000	17000	12000	31500	22400	23600	21200	15000	31500	22400
WB 26	26	21200	16950	30000	21200	23700	16950	45000	31500	33500	30000	21200	45000	31500
WB 32	32	31500	25200	45000	31500	35200	25200	67000	47500	50000	45000	31500	67000	47500
WB 40	40*	50000	40000	71000	50000	56000	40000	106000	75000	80000	56000	40000	85000	60000
WB 45	45*	63000	50000	90000	63000	71000	50000	132000	95000	100000	71000	50000	106000	75600

* Disponibili solo in versione saldata.
* Available only in welded version.

LIMITAZIONI ALL'USO DELLE BRACHE

DEMANDING CONDITIONS

Se l'imbragatura è sottoposta a temperature estreme, carichi asimmetrici o a spigoli vivi, è necessario ridurre i valori indicati in tabella, utilizzando i fattori sotto riportati.

If the chain slings are used in severe conditions, as high temperatures, asymmetric load distribution or sharp edges, the maximum load capacity values must be reduced by the load factor below.

Temperatura Temperature	-40°C ÷ 200°C	200°C ÷ 300°C	300°C ÷ 400°C
Fattore di carico Load factor	1	0,9	0,75
Distribuzione asimmetrica del carico Asymmetric load distribution	<p>La portata della braca deve essere diminuita di un braccio. Nel caso di brache a 3-4 bracci, la portata sarà quella di una braca a 2 bracci della catena corrispondente. Nel caso di brache a 2 bracci, la portata sarà quella della braca ad un braccio. Se la distribuzione del carico non è chiara, considerare sempre la portata della braca ad 1 braccio.</p> <p>The capacity of the sling should be decreased to a leg. In the case of 3 - 4 legs slings, the capacity will be as a 2 legs sling of the corresponding chain. In the case of 2 legs slings, the capacity will be of 1 leg sling. If the distribution of the load is not clear, always consider the capacity of 1 leg sling.</p>		
Sollevamento con catena a contatto con spigoli Edge load	 R > 2 x Ø catena/chain	 R > Ø catena/chain	 R < Ø catena/chain
Fattore di carico Load factor	1	0,7	0,5
Shock	Shock leggero Slight shock	Shock medio Medium shock	Shock pesante Heavy shock
Fattore di carico Load factor	1	0,7	Non ammissibile Not permissible

Quando la catena viene avvolta su carichi tondi, il diametro del tondo deve essere almeno 3 volte il passo della catena. In caso contrario, la portata della braca deve essere ridotta del 50%.

When lifting with chains on lugs or on round loads, it is recommended to use a lug diameter of at least 3 x the pitch of the chain. If this is not a case, the working load limit must be reduced by 50%.

CARATTERISTICHE

SPECIFICATION

ORDER TEXT

Specific information related to the capacity required, lifting points, uneven distribution of the load in case of more chain legs, angle between the legs of the sling, abnormal temperatures.

EXAMPLE OF ORDER

Chain sling - 13 mm - double-leg chain sling with master link and clevis hook - length 1.600 mm
Sling code: WB 2AKH 13 L= 1.600 MM

DATI NECESSARI PER L'ORDINE

N° dei bracci, Dimensione della catena, Tipo di catena.
Informazioni particolari inerenti la portata totale richiesta, distribuzione non uniforme del carico nel caso di tiranti a più bracci, ampiezza dell'angolo tra i bracci di catena, temperature anormali.

Esempio di ordine

Tirante di catena D 13 mm, a 2 bracci, con campanella e 2 ganci a perno alle estremità, lunghezza L = 1600 mm.
Codice del tirante: WB 2AKH 13 L = 1600 mm.



I codici in **nero** indicano accessori terminali a occhio.
Black codes mean eye type bottom hooks



I codici in **blu** indicano accessori terminali a perno.
Blue codes mean clevis type bottom hooks



Catene e accessori - Grado 8

Chain and accessory system in G8

BRACHE DI CATENA WB

WB CHAIN SLINGS

WB 1AH
WB 1AKH

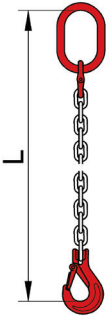

WB 2AH
WB 2AKH

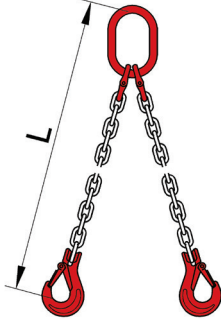

WB 3AH
WB 3AKH

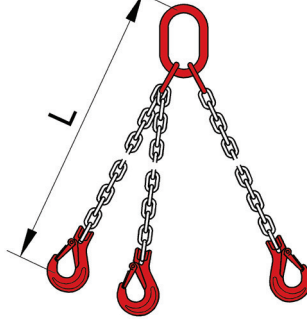

WB 4AH
WB 4AKH

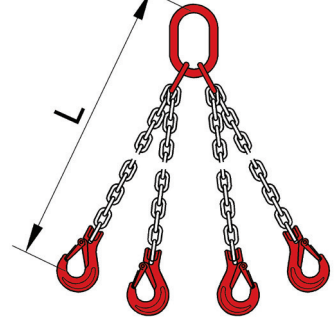

WB 1ALH
WB 1AKLH

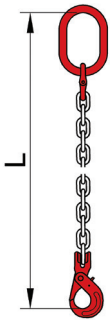

WB 2ALH
WB 2AKLH

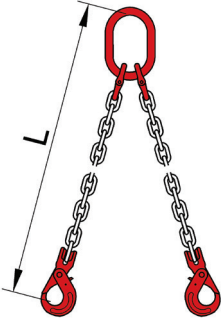

WB 3ALH
WB 3AKLH

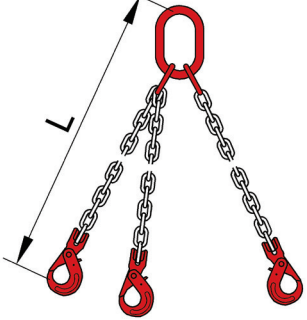

WB 4ALH
WB 4AKLH

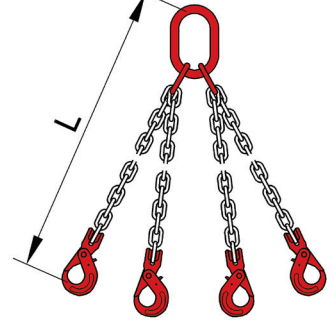

WB 1AHP
WB 1AKHP

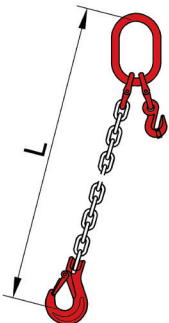

WB 2AHP
WB 2AKHP

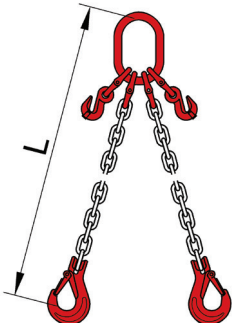

WB 3AHP
WB 3AKHP

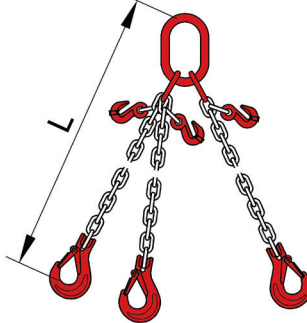

WB 4AHP
WB 4AKHP

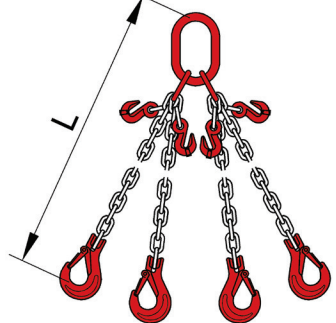

WB 1ALHP
WB 1AKLHP

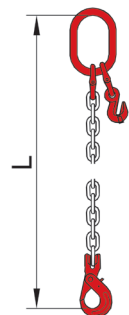

WB 2ALHP
WB 2AKLHP

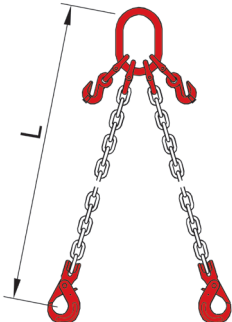

WB 3ALHP
WB 3AKLHP

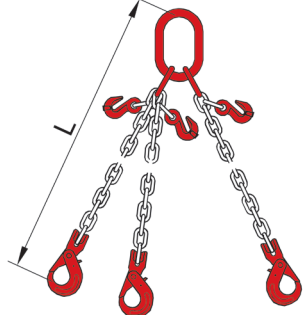

WB 4ALHP
WB 4AKLHP

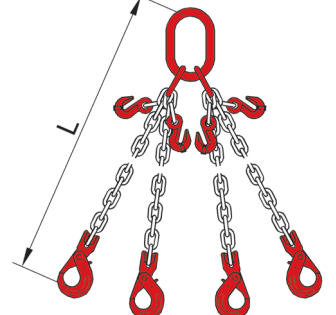

Catena G8 tipo WB

G8 chain WB type

Coefficiente di sicurezza 4:1
Safety factor 4:1

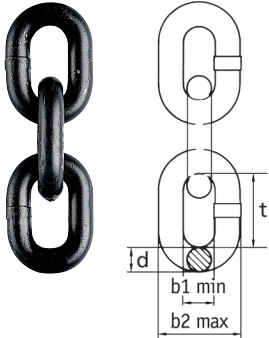

Tipo Type	Diametro nominale Nominal diameter d mm	Passo Pitch t mm	Larghezza Width		Portata WLL Kg	Carico di rottura Breaking force kN	Peso Weight Kg/m
			b1 min. mm	b2 max mm			
WB 7	7	21	9,1	25,9	1500	61,6	1,1
WB 8	8	24	10,4	29,6	2000	80,4	1,4
WB 10	10	30	13	37	3150	126	2,2
WB 13	13	39	16,9	48,1	5300	212	3,8
WB 16	16	48	20,8	59,2	8000	322	5,7
WB 20	20	60	26	74	12500	503	9
WB 22	22	66	28,6	81,4	15000	608	10,9
WB 26	26	78	33,8	96,2	21200	849	15,2
WB 32	32	96	41,6	118	31500	1290	23
WB 36	36	108	46,8	133	40000	1600	29
WB 40	40	120	52	148	50000	2000	36
WB 45	45	135	58,5	167	63000	2540	45,5

Campanella maggiorata W

W Enlarged master link

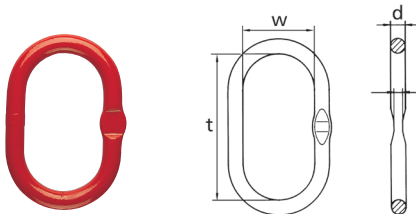

Tipo Type	Catena Chain 1 br. 2 br.		Portata WLL Kg	Dimensioni Dimensions			Peso Weight Kg
	Ø mm	mm		d mm	t mm	w mm	
W 0807	8	7	2750	15	120	70	0,50
W 1008	10	8	3500	16	140	80	0,67
W 1310	13	10	5500	20	160	95	1,20
W 1613	16	13	9400	27	190	110	2,65
MW 32	20	16	16000	33	230	130	4,80
MW 36	22	20	21200	38	275	150	7,50
AW 45	26	22	30800	45	340	180	12,80
AW 50	32	26	40000	50	350	190	16,50
AW 56	-	32	64000	60	400	200	27,00

Campanella tripla WT

WT Enlarged master link assembly

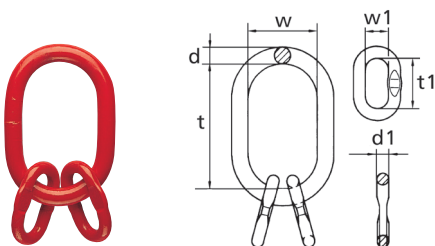

Tipo Type	Catena Chain 3/4 br. Ø mm	Portata WLL Kg	Dimensioni Dimensions						Peso Weight Kg
			d mm	d1 mm	w mm	w1 mm	t mm	t1 mm	
WT7	7	3150	19	13	75	25	135	54	1,16
WT8	8	4250	23	16	90	34	160	70	2,22
WT10	10	6700	27	18	100	40	180	85	3,36
WT13	13	11200	33	22	110	50	200	115	6,02
WT16	16	17000	36	26	140	65	260	140	9,94
VW 19-20	20	34100	50	33	190	70	350	150	22,8
VW 22	22	40000	50	36	190	75	350	170	25,1
VW 26	26	56000	60	40	200	80	400	170	41
VW 32	32	85000	70	50	250	100	460	200	66

Maglia di giunzione CL

CL Connecting link

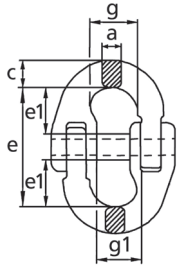
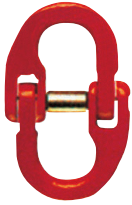

Tipo Type	Portata WLL Kg	Dimensioni Dimensions						Peso Weight Kg
		a mm	c mm	e mm	e1 mm	g mm	g1 mm	
CL 07	1500	8,8	10,5	51	20	20,5	17,8	0,10
CL 08	2000	9,5	12	61	25	23	19	0,25
CL 10	3150	12	12,5	72,5	30	27,5	23,8	0,35
CL 13	5300	17	20	88	36	33	28	0,68
CL 16	8000	20,5	22	103	40,5	39,5	34,3	1,10
CL 20	12500	23	23	116	48	47	44	1,70
CL 22	15000	26,5	26,5	133	51	55	49	2,20
CL 26	21200	31,5	31,5	148	60	66	60	4,20
CL 32	31500	37	37	183	69	79	67	7,19

Gancio ad occhio CA

CA Eye sling hook

- Con sicurezza forgiata.
- With forged safety latch.

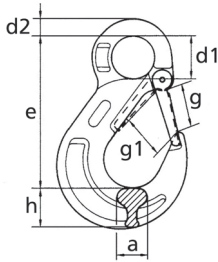

Tipo Type	Portata WLL Kg	Dimensioni Dimensions							Peso Weight Kg
		a mm	d1 mm	d2 mm	e mm	g mm	g1 mm	h mm	
CA 08	2000	19	25	11	95,5	29,5	24,5	27	0,50
CA 10	3150	23,5	34	14	120,5	35,7	29	33	0,90
CA 13	5300	29	42,5	17,5	150	43,5	35,4	40	1,50
CA 16	8000	35,5	52	22	183	52,5	44	49	2,75
CA 20	12500	42	62	25	217,5	60	54	55	4,50
CA 22	15000	51,5	60	30	224	70	62	60	7,10
HSW 26	21200	70	70	35	259	77	73	75	12,80
HSW 32	40000	82	66	45	299	91	87	97	27,90

Gancio autobloccante CRO

CRO Self locking hook

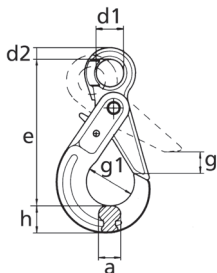

Tipo Type	Portata WLL Kg	Dimensioni Dimensions							Peso Weight Kg
		a mm	d1 mm	d2 mm	e mm	g mm	g1 mm	h mm	
CRO 08	2000	20	25	12	135	34	43	26	0,936
CRO 10	3150	25	33	16	168	45	56	30	1,626
CRO 13	5300	35	40	20	205	51	69	40	3,250
CRO 16	8000	36	50	27	251	60	80	50	6,050
CRO 20	12500	60	60	30	290	70	90	67	10,500
CRO 22	15000	62	70	32	322	80	100	70	14,400

Gancio accorciatore CD

CD Grab hook

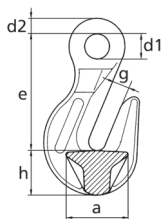

Tipo Type	Portata WLL Kg	Dimensioni Dimensions						Peso Weight Kg
		a mm	d1 mm	d2 mm	e mm	g mm	h mm	
CD 08	2000	30	16	10	60	10	24	0,23
CD 10	3150	44	21	11	80	13	31	0,59
CD 13	5300	53	26	16	104	17	38	1,24
CD 16	8000	64	30	19	129	20	60	2,6
CD 20	12500	85	36	22	153	23	65	4,2
CD 22	15000	87	38	25	180	27	68	5,3
CD 26	21200	100	55	36	213	30	88	13,2

Gancio fonderia CY

CY Foundry hook

- Utilizzare esclusivamente nei casi consentiti dalla legge.
- To use only when allowed by law.

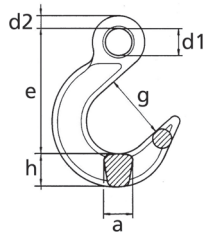

Tipo Type	Portata WLL Kg	Dimensioni Dimensions						Peso Weight Kg
		a mm	d1 mm	d2 mm	e mm	g mm	h mm	
CY 08	2000	25	18	13,5	125	64	31	0,92
CY 10	3150	23	32	14	150	76	34	1,77
CY 13	5300	38	27	19	173	89	45	2,82
CY 16	8000	45	47	24	210	102	50	5,03
CY 20	12500	54	56	28	260	114	65	7,6
CY 22	15000	63	55	32	275	127	70	12,3
CY 26	21200	72	62	35	305	136	80	17,9
CY 32	31500	84	70	38	330	153	95	27,3

Gancio a perno CB

CB Clevis sling hook

- Con sicurezza forgiata.
- With forged safety latch.

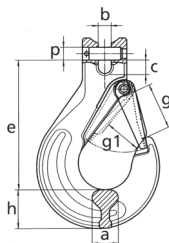

Tipo Type	Portata WLL Kg	Dimensioni Dimensions							Peso Weight Kg	
		a mm	b mm	c mm	e mm	g mm	g1 mm	h mm		p mm
CB 08	2000	19	8,7	9,8	86,3	29,5	25,5	27	9	0,53
CB 10	3150	23,5	12,2	13,5	105	35,7	30,5	33	13	0,95
CB 13	5300	28,5	15,3	17	128,5	43,5	41	40	16	1,67
CB 16	8000	37	18	22	155	56	45	48	20	3,00
CB 20	12500	46	23	26	183	61	52	52	24	5,70
CB 22	15000	50	24,5	29	213	72	62	62	27	8,80
CB 26	21200	60	30	34	230	77	73	75	30	13,5

Gancio autobloccante CRF

CRF Self locking hook

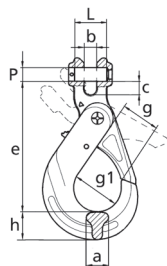

Tipo Type	Portata WLL Kg	Dimensioni Dimensions							Peso Weight Kg	
		a mm	b mm	c mm	e mm	g mm	g1 mm	h mm		PxL mm
CRF 7-8	2000	20	9	10	123	34	43	26	9x22,5	0,93
CRF 10	3150	25	12	14	143	45	56	30	13x31,5	1,58
CRF 13	5300	35	15	17	180	51	69	40	16x42	3,2
CRF 16	8000	36	19	20	215	60	80	50	21x51,5	5,9
CRF 20	12500	60	23	26	253	70	90	67	24x73	9,8
CRF 22	15000	62	26	32	287	80	100	70	26x72	14,4

Accorciatore CX con dispositivo di sicurezza

CX Grab hook with safety latch

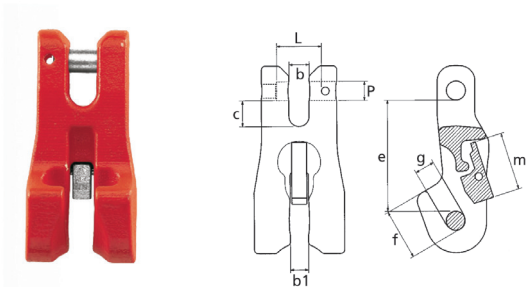

Tipo Type	Portata WLL Kg	Dimensioni Dimensions							PxL mm	Peso Weight Kg
		b mm	b1 mm	c mm	e mm	f mm	g mm	m mm		
CX 07S	1500	9,5	9,5	10	56	23,5	9,5	29	9x22,5	0,48
CX 08S	2000	9,5	9,5	10	56	23,5	9,5	29	10x22,5	0,48
CX 10S	3150	12	12	14,5	78	32,5	12	36	13x31,5	1,12
CX 13S	5300	15,5	15,5	18	90	44	15,8	35	16x42	1,83
CX 16S	8000	21	19	21	106	50	19	38	21x51,5	2,83

Gancio accorciatore CF

CF Clevis grab hook

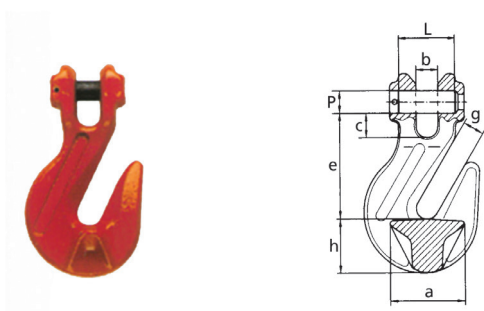

Tipo Type	Portata WLL Kg	Dimensioni Dimensions							PxL mm	Peso Weight Kg
		a mm	b mm	c mm	e mm	g mm	h mm			
CF 08	2000	30	9	10	50	10	24	9x22,5	0,27	
CF 10	3150	44	13	14	72	13	31	13x31,5	0,75	
CF 13	5300	53	17	17	88	17	38	16x42	1,35	
CF 16	8000	64	21	20	111	20	60	21x61,5	2,8	
CF 20	12500	85	24	24	130	24	65	24x61,5	4,8	
CF 22	15000	87	26	26	139	26	68	26x72	5,65	
CF 26	21200	100	30	35	190,5	30,5	90	30x80	13,5	

Anello a omega CZ

CZ Coupling ring

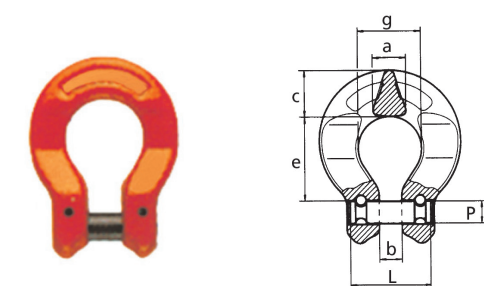

Tipo Type	Portata WLL Kg	Dimensioni Dimensions					PxL mm	Peso Weight Kg
		a mm	b mm	c mm	e mm	g mm		
CZ 08	2000	11	8,7	18	32	24	9x22,5	0,18
CZ 10	3150	14	12,5	19	44	32	13x31,5	0,35
CZ 13	5300	17	15	25	55	40	16x42	0,72
CZ 16	8000	22	19	30	65	50	21x61,5	1,20

Catene e accessori - Grado 8

Chain and accessory system in G8

TIPO WB

WB TYPE

Gancio CJ per fasce di poliestere

CJ Hook for web slings



Colore fascia Web colour	Tipo Type	Portata WLL Kg	Dimensioni Dimensions										Peso Weight Kg
			a mm	a1 mm	b mm	b1 mm	c mm	e mm	g mm	g1 mm	h mm		
	CJ 01	1000	17	16	78	41	12	87	26	31	20	0,7	
	CJ 02	2000	21	17	91	55	19	105	31	40	26	1,2	
	CJ 03	3000	25	25	113	55	21	118	37	50	32	2,2	
	CJ 04	4000	36	36	133	70	40	147	43	59,5	40	4,5	
	CJ 05	5000	36	36	133	70	40	147	43	59,5	40	4,5	
	CJ 06	6000	36	36	133	70	40	147	43	59,5	40	4,5	
	CJ 08	8000	40	42	188	105	50	200	65	80	60	9,7	
	CJ 10	10000	40	42	188	105	50	200	65	80	60	9,7	

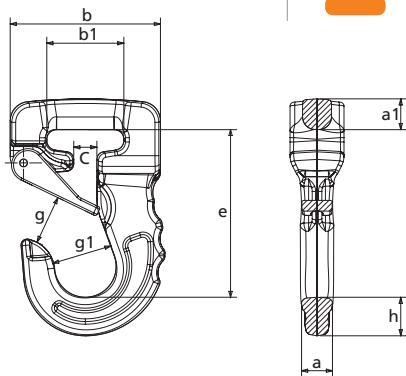

Maglia di giunzione CLS per brache di poliestere

CLS Connecting link for web slings



Tipo Type	Portata WLL Kg	Catena Chain mm	Dimensioni Dimensions					Peso Weight Kg
			A mm	B mm	C mm	D mm	L mm	
CLS 08	2000	(7) 8	10,5	24	40	20	62	0,32
CLS 10	3150	10	12	28	50	25	78	0,60
CLS 13	5300	13	17	33	60	30	97	1,10
CLS 16	8000	16	21	42	75	36	118	2,10
CLS 20	12500	20	23	52	82	40	134	2,30
CLS 22	15000	22	27	68	125	43	177	3,00

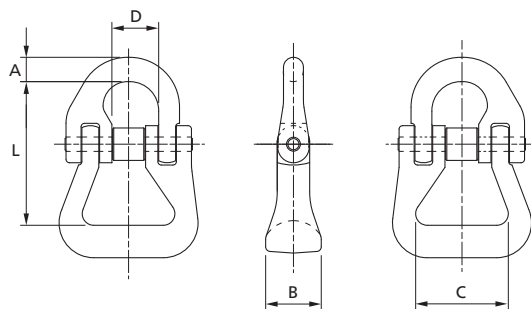

Catene e accessori - Grado 8

Chain and accessory system in G8

PARTI DI RICAMBIO TIPO WB

SPARE PARTS WB TYPE

Sicurezza forgiata CKS

CKS Safety catch set

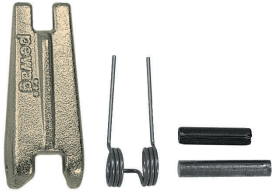

Tipo Type	Accessori d'utilizzo Accessories of use		
CKS 08	CA 08	CB 08	CJ 01
CKS 10	CA 10	CB 10	CJ 02-03
CKS 13	CA 13	CB 13	CJ 04-05-06
CKS 16	CA 16	-	-
CKS 16B	-	CB 16	-
CKS 20	CA 20	CB 20	-
CKS 22	CA 22	CB 22	CJ 08-10
CKS 26	CA 26	CB 26	-

Sicurezza CKSL per ganci autobloccanti

CKSL Safety catch set for self locking hooks



Tipo Type	Accessori d'utilizzo Accessories of use	
CKSL 08	CRF 08	CRO 08
CKSL 10	CRF 10	CRO 10
CKSL 13	CRF 13	CRO 13
CKSL 16	CRF 16	CRO 16
CKSL 20	CRF 20	CRO 20
CKSL 22	CRF 22	CRO 22

Kit perno e spina CKP

CKP devis load pin

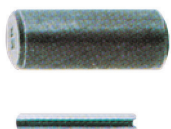

Tipo Type	Accessori d'utilizzo Accessories of use		
CKP 08	CB 08	CRF 08	SC 7-8
CKP 10	CB 10	CRF 10	SC 10
CKP 13	CB 13	CRF 13	SC 13
CKP 16	-	CRF 16	SC 16
CKP 16B	CB 16	-	-
CKP 20B	CB 20	CRF 20	-
CKP 22	CB 22	CRF 22	-
CKP 26	CB 26	-	-

Kit perno e bussola PSC per maglie di giunzione

PSC bolts and safety catch for connecting link



Tipo Type	Accessori d'utilizzo Accessories of use	
PSC 07	CL 07	
PSC 08	CL 08	CLS 08
PSC 10	CL 10	CLS 10
PSC 13	CL 13	CLS 13
PSC 16	CL 16	CLS 16
PSC 20	CL 20	CLS 20
PSC 22	CL 22	CLS 22
PSC 26	CL 26	
PSC 32	CL 32	